

Congratulations !

You have purchased the latest in Handheld Conductivity-TDS-Salinity-Temperature instrumentation. We trust that your new **WP-84** will give you many years of reliable service.

The **WP-84** is a breeze to operate. This manual has been designed to help you get started, and also contains some handy application tips. If at any stage you require assistance, please contact either your local TPS representative or the TPS factory in Brisbane.

The manual is divided into the following sections:

1. **Table of Contents**

Each major section of the handbook is clearly listed. Sub-sections have also been included to enable you to find the information you need at a glance.

2. **Introduction**

The introduction has a diagram and explanation of the display and controls of the **WP-84**. It also contains a full listing of all of the items that you should have received with your **WP-84**. Please take the time to read this section, as it explains some of items that are mentioned in subsequent sections.

3. **Main Section**

The main section of the handbook provides complete details of the **WP-84**, including operating modes, calibration, troubleshooting, specifications, and warranty terms.

4. **Appendices**

Appendices containing background information and application notes are provided at the back of this manual.



TPS Pty Ltd

ABN 30 009 773 371

4 Jamberoo Street
Springwood, Brisbane,
Australia, 4127

Phone : (07) 32 900 400

International : 61 7 32 900 400

Fax : (07) 3808 4871

International : 61 7 3808 4871

Email : tps@tps.com.au

Web : www.tps.com.au

Contents

1. Introduction	5
1.1 WP-84 Display and Controls	5
1.2 Unpacking Information	7
1.3 Specifications	8
2. WP-84 Menu Structure	10
3. Operating Modes	11
3.1 Selecting Conductivity, TDS (setting factor) or Salinity Mode	11
4. Conductivity (TDS/Salinity) Calibration	12
4.1 Calibration Procedure	12
4.2 Calibration Notes	14
4.3 Calibration Messages	14
5. Temperature Calibration	15
5.1 Calibration Procedure	15
5.2 Calibration Notes	15
5.3 Calibration Messages	16
6. ATC Coefficient	17
6.1 Setting the ATC Coefficient	17
6.2 Calculating the ATC Coefficient of a Solution	18
7. Good Laboratory Practices (GLP)	19
7.1 To recall GLP information on the display	19
7.2 Failed Calibration	19
7.3 Printing GLP Information to the RS232 Port	20
7.4 Instrument Serial Number	20
7.5 Additional GLP Features	20
8. Notepad Function	21
8.1 Recording Readings into the Notepad	21
8.2 Recalling Records from the Notepad	21
8.3 Erasing Records from the Notepad	21
8.4 Printing Records from the Notepad to the RS232 Port	22
9. Automatic Data logging	23
10. RS232 Port	25
10.1 Setting the Baud Rate	25
10.2 Sending Readings to the RS232 Port	25
10.3 RS232 Configuration	25
10.4 Communication and Statistical Software	25
10.5 Commands	26
10.6 Data Format	27
10.7 GLP Data Format	27

10.8	Importing Data into Microsoft Excel	28
11.	Battery Saver Function	30
12.	Recharging the Battery	31
13.	Clock Function	32
13.1	Setting the Clock	32
13.2	Displaying or Hiding the Clock	32
14.	Selecting k=0.1 or k=10 Sensors.....	33
15.	Initialising the WP-84	34
16.	Instrument firmware version number.....	34
17.	Troubleshooting.....	35
17.1	General Errors.....	35
17.2	Conductivity/TDS/Salinity Troubleshooting	36
17.3	Temperature Troubleshooting.....	38
18.	Appendices.....	39
18.1	Care, Cleaning and Maintenance of Conductivity Sensors	39
18.2	Replatinising Conductivity Sensors	40
19.	Warranty	41

1. Introduction

1.1 WP-84 Display and Controls

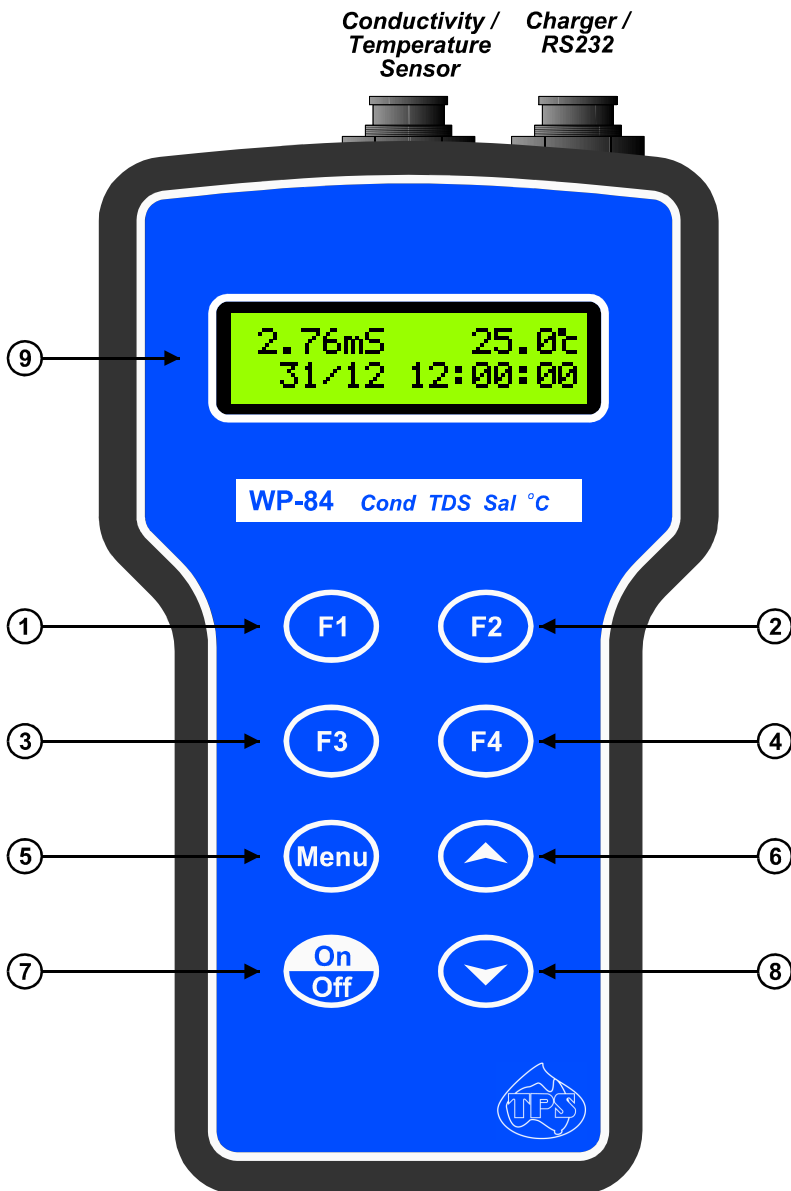



Press to record readings into memory. See section 8.1.



Press to show or hide the date and time. See section 13.2.

Also used to select $k=0.1$ or $k=10$ sensor, when the standard $k=1$ sensor is not being used.



Press to start or stop automatic logging. See section 9.

Alternatively, press to transmit current reading plus date and time to the RS232 port. See section 10.2.





Only used within the menu system on the **WP-84**.



Press to access the user-friendly menu system which makes the **WP-84** a breeze to operate.



The  and  keys are used when calibrating temperature readout (section 5), setting the clock (section 13.1), setting the automatic logging period (section 9), and displaying GLP information (section 7.1).

The  key is also used to initialise the **WP-84** at turn-on. See section 15.



Switches the **WP-84** on and off.

⑨ Display

32 character alpha-numeric display with user-friendly menu and prompting system. Shows Conductivity/TDS/Salinity and Temperature simultaneously. Date and time can also be displayed.

1.2 Unpacking Information

Before using your new **WP-84**, please check that the following accessories have been included:

	Part No
1. WP-84 Conductivity-TDS-Sal-Temp instrument.....	122159/1 122159/3 122159/5
2. Conductivity/ATC/Temperature Sensor: k=1 1, 3 or 5m cable (see cable label for part No) k=10 1, 3 or 5m cable k=0.1 1, 3 or 5m cable	
3. Conductivity Standard, 200mL: 2.76 mS/cm	122306
or 58.0 mS/cm	122315
or 150.0 uS/cm.....	122320
4. Battery charger	130037
5. Manual	

*Options that may have been ordered with your **WP-84**:*

1. Extended cable	130040
2. RS232 Serial Interface Cable	130041
3. Communication software for Windows 95 and later	130086
4. USB to Serial Adaptor (requires 130041 also)	130087
5. Hard Carry Case.....	130059
6. Battery charger lead for 12V cigarette lighter socket	130046
7. Battery charger lead for 12V DC, with battery clips.....	130052
8. Solar Panel	130012

1.3 Specifications

Conductivity

Ranges4 ranges, with automatic range selection.
k=0.1 Sensor ..0 uS/cm to 2000 uS/cm
k=1.0 Sensor ..0 uS/cm to 20.00 mS/cm
k=10 Sensor ..0 uS/cm to 200.0 mS/cm

Resolution.....0.05% of selected range

Accuracy.....±0.5% of full scale of selected range at 25 °C

TDS

Ranges:4 ranges, with automatic range selection.
k=0.1 Sensor ..0 ppM to 1000 ppM
k=1.0 Sensor ..0 ppM to 10.00 ppK
k=10 Sensor ...0 ppM to 100.0 ppK

Resolution.....0.1% of selected range

Accuracy.....±0.5% of full scale of selected range at 25 °C

Salinity

.....k=0.1 Sensor 0 % to 0.10 %
0 PSU to 1.0 PSU
k=1.0 Sensor ..0 % to 1.19 %
0 PSU to 11.9 PSU
k=10 Sensor ..0 % to 8.00 %
0 PSU to 80.0 PSU

Resolution.....0.01% / 0.1 PSU

Accuracy.....±0.5% of full scale of selected range at 25 °C

Temperature

Range.....-10.0 to 120.0 °C (Sensor limit 60 °C)

Resolution.....0.1 °C

Accuracy.....±0.2 °C

General Specifications

Temperature Compensation:

Conductivity/TDS/Salinity.. Automatic -5 to 70 °C

Calibration:

Conductivity/TDS/Salinity.....	Auto Standard Recognition 150uS/cm, 1413uS/cm, 2.76mS/cm, 12.88mS/cm, 58.0mS/cm
Conductivity Span Range	k=0.1 Sensor: k=0.075 to k=0.133 k=1.0 Sensor: k=0.75 to k=1.33 k=10 Sensor: k=7.5 to k=13.3
Temperature	Use a reference thermometer.
Temperature Sensor Offset	-10.0°C to +10.0°C
Memory	3600 readings including date and time.
Automatic Data logging	User-set for one reading every 1 to 90 seconds, 1 to 90 minutes, or 1 to 24 hours.
RS232 Output	300, 1200, 9600 & 19200 baud. 8 bits, no parity, 1 stop bit, XON/XOFF Protocol.
Clock.....	Calendar clock displays date, month, hours, minutes & seconds. Year is recorded in memory and transmitted to the RS232 port, but is not displayed.
Battery Saver	On : Auto switch-off after 5 minutes. Off : Continuous use. Bar Graph display of battery charge level. Readout of battery voltage available for troubleshooting.
Good Laboratory Practices.....	Date, Time and Value of last Conductivity and Temperature calibration are stored, and can be recalled or sent to the RS232 port at any time.
Power.....	6V NiMH Rechargeable Battery for approximately 40 hours operation.
Dimensions	195 x 110 x 55 mm
Mass	Instrument only : Approx 520g Full Kit : Approx 2.5kg
Environment.....	Temperature : 0 to 45 °C Humidity : 0 to 95 % R.H.

2. WP-84 Menu Structure

A detailed breakdown of the menu system of the **WP-84** is shown below. This diagram provides a quick reference for the **WP-84** menu functions.

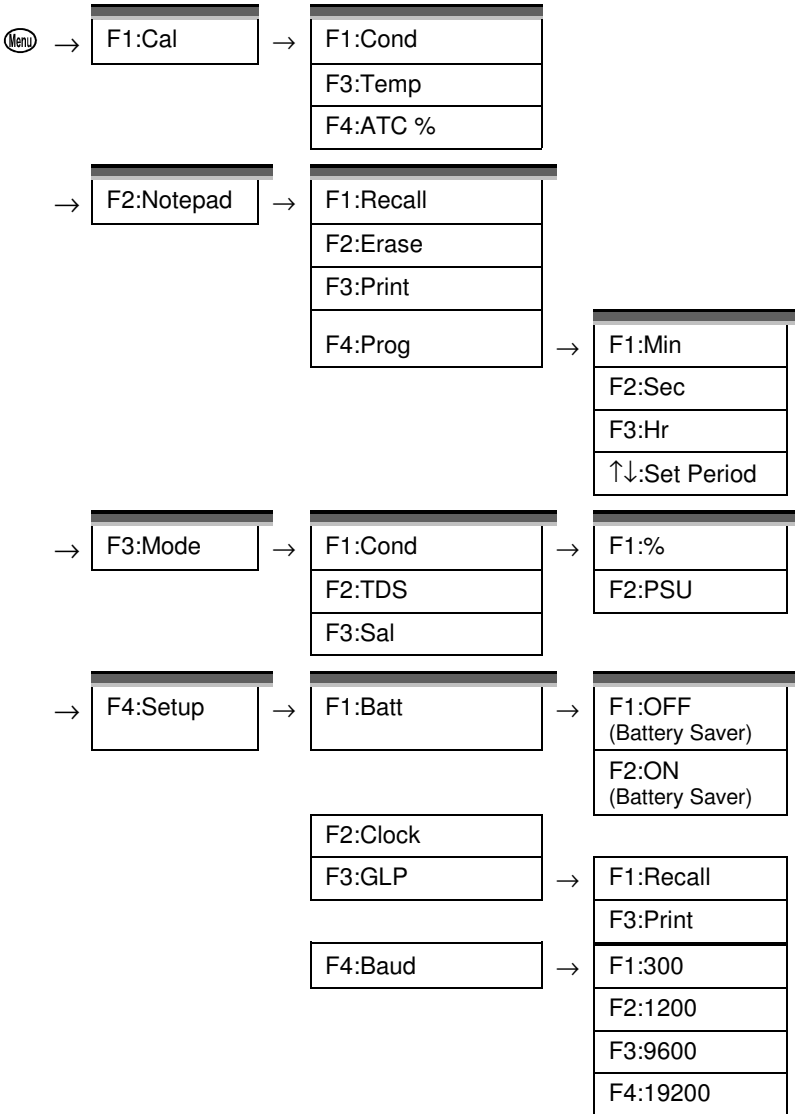

3. Operating Modes

3.1 Selecting Conductivity, TDS (setting factor) or Salinity Mode

To select Conductivity, TDS or Salinity mode...

Select the Mode menu
(Menu) → **F3:Mode**...

1. Press **F1** to select the Mode Menu.

F1:Cond. **F2:TDS**
F3:Sal.

2. Press **F1** to select Conductivity mode.
Press **F2** to select TDS mode.
You will now be asked to enter the TDS Factor.

→0.65← TDS factor
↑↓:Set **F1:Save**

Press **F3** to select Salinity mode menu.

Select units
F1:% **F2:PSU**

Press **F1** to select % units.
Press **F2** to select PSU units.

Press (Menu) to quit and retain the current selection.

4. Conductivity (TDS/Salinity) Calibration

To achieve accurate Conductivity/TDS/Salinity results, the **WP-84** requires calibration to an allowable Conductivity standard. The TDS and Salinity values are derived from the Conductivity reading and do not require a separate calibration. The conductivity of a solution varies with temperature. The **WP-84** uses Automatic Temperature Compensation (ATC) referenced to the fixed temperature of 25°C.

A “*” in place of the decimal point indicates that the Conductivity/TDS/Salinity readout is not calibrated, or a past calibration has failed. The “ * ” will be removed once a Conductivity calibration has been successfully performed in Conductivity standard.

4.1 Calibration Procedure

1. Plug the Conductivity sensor into the **Conductivity** socket.
If a $k=0.1$ or $k=10$ sensor is being used, ensure that the **WP-84** is set to the correct k factor before using the instrument (see section 14).
2. Switch the meter on.
3. Rinse the Conductivity sensor in distilled water. Shake off as much water as possible. Blot the outside of the sensor dry. **DO NOT BLOT THE SENSOR WIRES.**
4. **Zero Calibration**
Let the sensor dry in air.
Select Conductivity Calibration. (Menu → **F1:Cal.** → **F1:Cond.**)
5. When the reading has stabilised at or near zero, press the **F1** key to calibrate.
A “ * “ will not be removed after a zero calibration.
6. **Standard Calibration**
Allowable Conductivity standards are 150 μ S/cm, 1413 μ S/cm, 2.76mS/cm, 12.88mS/cm and 58.0mS/cm, and should be selected according to your range of interest.
If the **WP-84** does not recognise the standard, it will display the message, “**NOT STD**” during calibration. Calibration will fail if this message is displayed.

For plastic bodied $k=1$ and $k=10$ sensors, place the sensor into a sample of Conductivity standard, so that it is immersed at least to the vent hole in the white plastic cover. The white plastic cover **MUST** be in place for correct readings.

For plastic bodied $k=0.1$ sensors, the white plastic cover **MUST** be removed for correct readings.

For glass bodied sensors, immerse the sensor at least to the vent hole in the glass body.

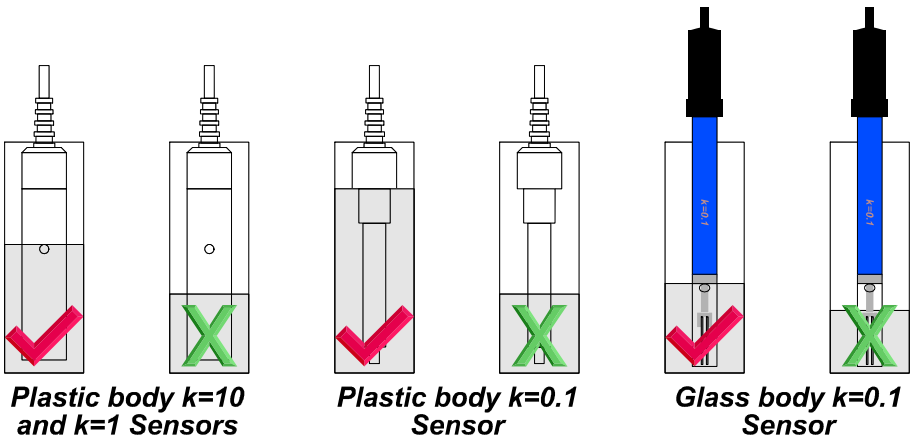

DO NOT place the sensor directly into the bottle of standard. Discard the used sample of standard after use. It is advisable to use a narrow sample vessel to minimise the use of standard solution.

7. Select Conductivity Calibration. (Menu) → **F1:Cal.** → **F1:Cond.**)
8. When the reading has stabilised, press the (F1) key to calibrate.
The * will now be replaced by a decimal point, if calibration was successful.
1. The **WP-84** is now calibrated for Conductivity and is ready for use in this mode.

4.2 Calibration Notes

1. A Zero calibration should be performed at least monthly. In low conductivity applications (where a zero error is particularly significant) a zero calibration may have to be done weekly.
2. A Standard calibration should be performed at least weekly. Of course, more frequent calibration will result in greater confidence in results.
3. The **WP-84** does not require re-calibration when alternating between Conductivity, TDS and Salinity modes.
4. All calibration information is retained in memory when the **WP-84** is switched off, even when the battery is removed. This information can be recalled or printed later using the GLP function (see section 6).
5. The **WP-84** displays the value of the standard to which it will attempt to calibrate. Ensure that the standard value displayed corresponds to the standard that you are using.
6. If the **WP-84** does not recognise the standard, it will display the message, "**NOT STD**" during calibration. Calibration will fail if this message is displayed.

4.3 Calibration Messages

1. If a Zero calibration has been successfully performed, the **WP-84** will display the following message and the zero value of the sensor. For example...

```
Calibrate OK  
Zero= 0.00 uS
```

2. If a Standard calibration has been successfully performed, the **WP-84** will display the following message and the k factor of the sensor. For example...

```
Calibrate OK  
k=1.00
```

3. If a Standard calibration has failed, the **WP-84** will display the following message and the failed k factor of the sensor. For example...

```
Calibrate fail  
k=1.50
```



5. Temperature Calibration

5.1 Calibration Procedure

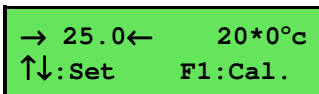
1. Plug the Conductivity/Temperature sensor into the **Sensor** socket.
2. Place the sensor into a beaker of room temperature water, alongside a good quality mercury thermometer. Stir the sensor and the thermometer gently to ensure an even temperature throughout the beaker.
3. Select Temperature Calibration (Menu → F1:Cal. → F3:Temp).
4. The reading from the sensor is now displayed on the right of the display, and the value you are going to set is shown on the left. For example...



→ 25.0← 20*0°C
↑↓:Set F1:Cal.

5. When the reading on the right has stabilised, press the  and  keys until the reading on the left shows the same temperature as the mercury thermometer.
6. Press the  key to calibrate the temperature readout.

Alternatively, press  to quit and retain the current calibration settings.

The * will now be replaced by a decimal point, if calibration was successful.

Alternatively, press the  key to abort temperature calibration.

5.2 Calibration Notes

1. Temperature calibration information is retained in memory when the **WP-84** is switched off, even when the battery is removed. This information can be recalled or printed later using the GLP function (see section 7).
2. Temperature does not need to be re-calibrated unless the sensor is replaced or the meter is initialised.

5.3 Calibration Messages

1. If a temperature calibration has been successfully performed, the **WP-84** will display the following message and the offset value of the sensor.

```
Calibrate OK  
Offset= 1.0°C
```

2. If a temperature calibration has failed, the **WP-84** will display the following message and the failed offset value of the sensor.

```
Calibrate Failed  
Offset= 10.5°C
```

6. ATC Coefficient

The Automatic Temperature Compensation (ATC) Coefficient is the rate at which the WP84 compensates for temperature effects on the Conductivity of the solution. The following all affect the ATC Coefficient of a solution...

- The type of salts dissolved in the solution.
- The concentration of the salts dissolved in the solution.
- The temperature of the solution.

It is therefore impossible to set a single ATC Coefficient in the factor which will be correct for all solutions which the **WP-84** will be used to test.

The ATC Coefficient is set to 2.0 %/°C in the factory. This figure is suitable for environmental waters whose predominant dissolved salt is Sodium Chloride at moderate concentrations, being measured between approximately 15 and 30 °C.

The calculation of Salinity from the Conductivity reading incorporates the ATC Coefficient as defined for sea water. The user set ATC Coefficient is not used.



6.1 Setting the ATC Coefficient

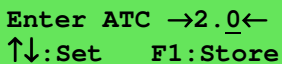

1. Select the ATC entry screen (Menu → F1:Cal. → F4:ATC %).
2. The ATC entry setting screen is displayed...



```

Enter ATC ->2.0<-
↑↓:Set   F1:Store
  
```

Use the  and  keys to scroll to the desired ATC Coefficient setting. The available range is 0.0 to 4.0 %/°C.

3. Press  to store the new setting.
Press  to quit and retain the current setting.

Note

The ATC Coefficient is set to 2.0 %/°C during calibration and returns to the user setting when finished.

6.2 Calculating the ATC Coefficient of a Solution

1. Set the ATC Coefficient to zero using the procedure detailed in section 6.1.
2. Ensure that the temperature function has been calibrated (see section 5.1). The conductivity function does not need to be calibrated at this point.
3. Warm or cool the solution to approximately 5 °C below the temperature at which you expect to take sample measurements. Record the Conductivity and Temperature readings once both have become stable.
4. Warm the solution to approximately 5 °C above the temperature at which you expect to take sample measurements. Record the Conductivity and Temperature readings once both have become stable.
5. Apply the following formula, where C1 and T1 are the first readings taken, and C2 and T2 are the second readings taken...

$$\text{ATC Slope} = 100 \times \left(10^{\left(\frac{\text{Log} \left[\frac{C2}{C1} \right]}{T2 - T1} \right)} - 1 \right)$$

6. Enter the result that is obtained as the ATC Coefficient of the solution, as per the procedure detailed in section 6.1.

Note

To assist in calculating the ATC Slope, the following information can be entered into a spreadsheet. This example has been specifically written for Microsoft™ Excel™, although the syntax should be similar for other spreadsheet software.

	A	B
1	Conductivity 1	<Enter first Conductivity reading>
2	Temperature 1	<Enter first Temperature reading>
3	Conductivity 2	<Enter second Conductivity reading>
4	Temperature 2	<Enter second Temperature reading>
5	ATC Slope	=100*((10^((LOG10(B3/B1))/(B4-B2)))-1)

A ready-made file can be downloaded from the Downloads section of the TPS Web Site : <http://www.tps.com.au/downloads>



7. Good Laboratory Practices (GLP)

The **WP-84** keeps a record of the date and time of the last Conductivity and Temperature calibrations as part of GLP guidelines.

7.1 To recall GLP information on the display

1. Select the GLP menu (Menu) → **F4: Setup** → **F3: GLP**).
2. Select **F1: Recall** from the menu.
3. The instrument model, firmware version number, and instrument serial number are displayed, along with a prompt describing how to scroll through the GLP information. For example...

```
WP84 V4.0 S1234
↓:More ↑:Back
```

4. Press the  key to sequentially scroll through the GLP information for all parameters. Press the  key to scroll back to previous data. The sequence of information displayed is shown over the page. Press (Menu) to abort at any time.

GLP display sequence...

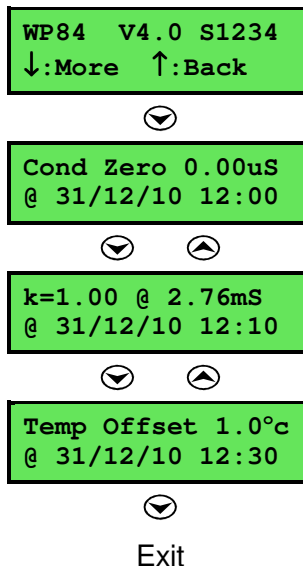

7.2 Failed Calibration

If calibration has failed, the GLP function will reset the date and time to zero. The **WP-84** still shows the results of the last successful calibration. For example...

```
Cond Zero 0.00uS
@ 00/00/00 00:00
```

or

```
k=1.00 @ 2.76mS
@ 00/00/00 00:00
```

Note that these calibration values are still used if further measurements are taken without re-calibrating.

7.3 Printing GLP Information to the RS232 Port

The GLP information stored in the instrument's memory can be sent to a printer or PC via the RS232 port.

Ensure that the **WP84** RS232 cable is connected to the instrument and to the printer or PC.

1. Select the GLP menu (**Menu** → **F4:Setup** → **F3:GLP**).
2. Select **F3:Print** from the menu.
3. The GLP information is sent to the RS232 port in formatted ASCII text. For example...

```
WP84 V4.0 S1234 @ 31/12/10 13:00
Conductivity Zero= 0.00uS @ 31/12/10 12:00
Conductivity k= 1.00 @ 2.76mS @ 31/12/10 12:10
Temperature Offset= 1.0oC @ 31/12/10 12:30
ENDS
```

7.4 Instrument Serial Number

In case the serial number that is fitted to the rear of the **WP-84** is removed or becomes illegible, it is also available on the **WP-84** display.

- The serial number is displayed at turn-on, for example...

```
WP84 V4.0 S1234
Con TDS Sal Temp
```

where **S1234** is the serial number.

- The serial number is displayed when recalling the GLP information (section 7.1).
- The serial number is included on the print-out of GLP information (section 7.3).

7.5 Additional GLP Features

Another GLP requirement is to record the date and time of every reading. The **WP-84** does this when readings are recorded with the Notepad function (section 8) or the Automatic Logging function (section 9).

8. Notepad Function

8.1 Recording Readings into the Notepad

To record readings into the Notepad memory...

1. Press **F1** in normal display mode. The display should now look like this...(when in Conductivity mode)

```

2.76mS      25.0°C
F1:  1      12:00:00
  
```

2. Press **F1** to record the Conductivity/TDS/Salinity, Temperature, Date and Time into the notepad. This will be labelled as reading number 1.
3. Repeat steps 1 & 2 as often as required. The maximum number of readings that can be stored in the Notepad is 3600.

8.2 Recalling Records from the Notepad

To recall records from the Notepad onto the **WP-84** display...

1. Select the Notepad menu (**Menu** → **F2:Notepad**).
2. Select **F1:Recall** from the menu.
3. Record number 1 is now displayed, for example...

```

2.76mS      25.0°C
#  1        F2:Clock
  
```

4. Press **F2** to alternatively display the date and time or the data for this record.
 Press **▲** to move forward through the records.
 Press **▼** to move backward through the records.
 Press and hold the **▲** or **▼** keys to roll rapidly through the readings.

8.3 Erasing Records from the Notepad

To erase all records from the Notepad:

1. Select the Notepad menu (**Menu** → **F2:Notepad**).
2. Select **F2:Eraser** from the menu
3. The **WP-84** now asks if you are sure that you wish to erase all records...

```

Erase, You Sure?
F1:Yes  F2:No
  
```

- Press **F1** to erase all records from the Notepad.
 Press **F2** to quit without erasing the records from the Notepad.

8.4 Printing Records from the Notepad to the RS232 Port

1. Connect one end of the RS232 cable to the **Charger/RS232** socket of the **WP-84**. The charger, optional solar panel, or optional car battery lead can be connected into the spare socket on the cable for long term use, if required.
2. Connect the other end of the RS232 cable to an RS232 Printer, or to COM1 or COM2 of a PC.

When using a PC, it must have a software utility installed which can communicate with the RS232 port. Windows 95, 98 & ME are shipped with Hyper Terminal, which is suitable for this purpose.

3. Ensure that the baud rate for the printer or PC and the **WP-84** are the same.

If necessary, alter the baud rate of the **WP-84** (see section 10.1).

The **WP-84** uses XON/XOFF protocol. Ensure that the printer is set accordingly.

4. Select the Notepad menu (Menu → **F2:Notepad**).

5. Select **F3:Print** from the menu.

Printing starts as soon as **F3** is pressed. The display shows the word "**Printing**" until printing is completed.

Note

Downloading the recorded readings is as simple as clicking on the toolbar using the optional WinTPS RS232 Communication Software. This is part number 130086 and is available from TPS or your distributor.

9. Automatic Data logging

The **WP-84** can automatically log records into the Notepad. First the logging period must be programmed, then automatic logging can be started and stopped as required.

1. Select the Program menu (Menu → **F2:Notepad** → **F4:Prog.**).
2. The display should now look like this...

```

→00← F1:Min F2:Sec
↑↓:Period F3:Hr

```

3. Use the \uparrow and \downarrow keys to set the period at which the **WP-84** will automatically log records.
4. When the logging period has been correctly set, select whether this period is in minutes, seconds or hours.
 - Press **F1** to save the period as minutes.
 - Press **F2** to save the period as seconds.
 - Press **F3** to save the period as hours.

For example, if the period was set to 05, followed by **F2**, then the **WP-84** will automatically log a record every 5 seconds.
5. The **WP-84** will ask if the records are to be logged into the Notepad, or sent directly to the RS232 port.
 - Press **F1** to log records into the Notepad (maximum of 3600 readings).
 - Press **F1** to send records directly to the RS232 port.
6. The automatic logging function is now programmed, and can be started and stopped as required.
7. To start automatic logging, press **F3** in normal display mode.

If the **WP-84** is logging into the Notepad, the display will look like this...

```

2.76mS    25.0°C
Log# 1 12:00:00

```

The log number will increment and the **WP-84** will beep each time a reading is recorded.

Continued over the page...

Automatic Data logging, continued...

If the **WP-84** is sending records directly to the RS232 port, the display will look like this...

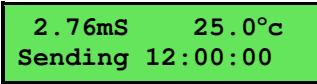

The **WP-84** will beep each time a record is sent to the RS232 port.

8. Press **F3** to stop automatic logging.

Notes

1. The clock must be set before the **WP-84** will allow automatic logging to start. The message “**Clock Not Set**” is displayed if the clock is not set.
2. The Battery Saver function (section 11) is disabled while the meter is in Automatic Data logging mode, to stop the meter switching off while logging data. Even when the memory is full and the meter stops logging, the Battery Saver function is still disabled. This allows the data to be downloaded and the memory to be reset remotely.

10. RS232 Port

10.1 Setting the Baud Rate

1. Select the RS232 Set-up menu (Menu → **F4:Setup** → **F4:Baud**).
2. The available baud rates are listed on the display...

```
F1:300  F2:1200
>F3:9600 F4:19200
```

The arrow shows the current selection.

3. Press (F1) to select 300 baud
Press (F2) to select 1200 baud
Press (F3) to select 9600 baud.
Press (F4) to select 19200 baud.
Press (Menu) to quit and retain the current setting.

10.2 Sending Readings to the RS232 Port

Press (F3) to instantly send readings to the RS232 port whenever the **WP-84** is in normal display mode. This function is disabled if the automatic logging period is set to greater than zero (see section 9).

Records can be sent directly to the RS232 port rather than stored in memory during automatic data logging. See section 9 for details.

10.3 RS232 Configuration

The **WP-84** RS232 configuration is 8 bits, No Parity, 1 Stop Bit, XON/XOFF Protocol.

10.4 Communication and Statistical Software

Communication between the **WP-84** and a PC can be handled with any RS232 communication software. **WinTPS** RS232 communication software for Windows® 95 and later is optionally available (part number 130086).

Once the data is saved to disk, the next problem is how to use it. The data sent by the **WP-84** is formatted in fixed-width columns that can be imported by programs such as Microsoft® Excel® and Lotus 123®.

Information on how to use the software and import data is provided in the manual provided with the **WinTPS** CD-ROM.

10.5 Commands

The following commands can be sent from a PC to the **WP-84**. Note that <cr> denotes carriage return and <lf> denotes a line feed.

Action	Command	Notes
Request current data	?D<cr>	Returns the current Conductivity/TDS/Salinity, Temperature, date and time from the WP-84 . The log number returned is set to Zero.
Request logged data	?R<cr>	Returns all logged records from the WP-84 memory. The data ends with the message ENDS <cr>
Erase logged data	?E<cr>	Erases all logged records from the WP-84 memory. Returns the message ERASED <cr> to confirm that the records have been erased.
Request status information	?S<cr>	Returns the model name, firmware version number, instrument serial number and number of logged readings in memory, eg: WP84♦♦V4.0♦S1234♦9999 <cr>, where ♦ are spaces. Note that the number of logged readings is right-justified.
Request GLP information	?G<cr>	Returns all calibration GLP information, plus the instrument model and current date (see section 10.6 for data format and hand-shaking).

10.6 Data Format

Data is returned to the RS232 port by the **WP-84** in the following format. Please note that a “♦” shown anywhere in this section denotes one space.

LLLL♦DDDDDDUUU♦TTTTT°C♦♦dd/mm/yy♦hh:mm:ss

where...

- LLLL** is the Log Number. Maximum 4 characters, right justified.
A Zero is sent for instant readings (section 10.2).
- DDDDDD** is the Conductivity/TDS/Salinity Data. Maximum 6 characters, right justified.
- UUU** is the Conductivity/TDS/Salinity unit description, either “uS♦”, “mS♦”, “ppM”, “ppK”, “%♦” or “PSU”
- TTTTTT** is the Temperature Data. Maximum 6 characters, right justified.
- °C** is the Temperature unit description.
- dd/mm/yy** is the date, month and year data.
- hh:mm:ss** is the hours, minutes and seconds data.

Notes

When requested by a PC with the ?D or ?R commands (section 10.5), each line of data is terminated with a carriage return.

When the data is sent by the **WP-84** using the Print function (section 8.4) or Send function (section 10.2), each line of data ends with a carriage return and a line feed.

10.7 GLP Data Format

GLP information is returned as 6 lines terminated by a carriage return. The computer must respond with a character after receiving each line. For example...

```
WP84 V4.0 S1234 @ 31/12/10 13:00
Conductivity Zero= 0.00uS @ 31/12/10 12:00
Conductivity k= 1.00 @ 2.76mS @ 31/12/10 12:10
Temperature Offset= 1.0°C @ 21/12/10 12:30
ENDS
```

10.8 Importing Data into Microsoft Excel

The following procedure details the method for importing a **WP-84** text data file into Microsoft® Excel®.

1. Start Microsoft® Excel® and select File → Open
2. In the “Files of type:” pull-down box, choose “Text Files (*.prn; *.txt; *.csv)”.
3. Navigate to the folder where your data file is stored and double-click it to start the Text Import Wizard.

Note: The default data folder for the WinTPS software is “C:\My Documents\WinTPS”.

4. In step 1 of the Text Import Wizard select “Fixed width”, as per the sample screen below, then press “Next >”.

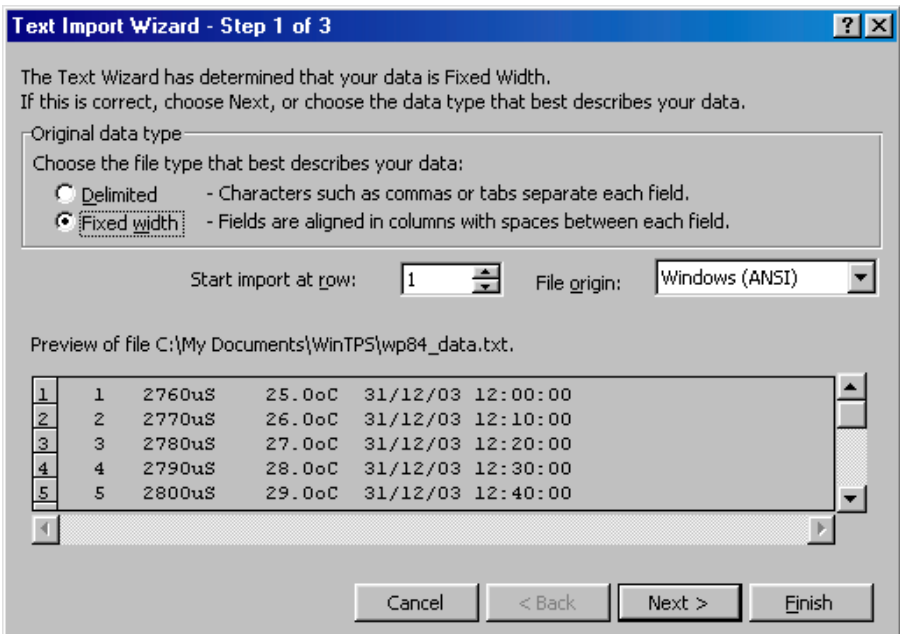

Continued over the page...

- Step 2 of the Text Import Wizard allows you to select the points at which each data field will break into a new column. The sample screens below show where TPS recommends the breaks be inserted.

Press “Next >” after the column breaks have been inserted.

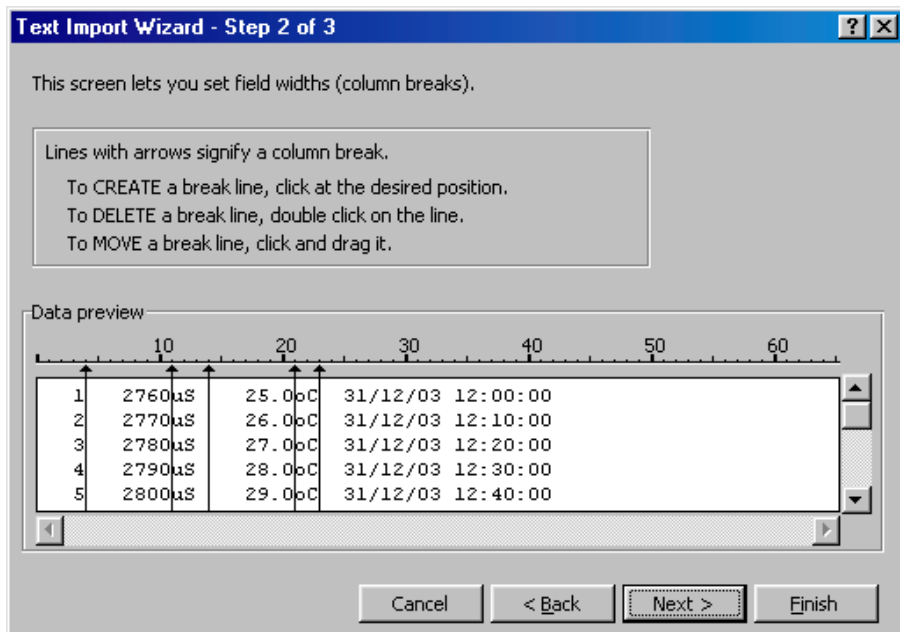

- Simply press “Finish” at step 3 of the Text Import Wizard. TPS recommends that the data format for each column be set once the data is in spreadsheet format.

For help on formatting the data columns, charting, graphing or other operations please consult the Microsoft® Excel® help file. Alternatively please contact TPS and we will try to provide further assistance.

11. Battery Saver Function

The **WP-84** is equipped with a battery saver function. If no button has been pressed for five minutes, the unit beeps and flashes the display for 20 seconds, and then shuts off. This function can be switched off for continuous use.

To enable or disable the battery saver function...

1. Select Battery Saver Set-up (Menu → **F4:Setup** → **F1:Batt**).
2. The battery saver menu is now displayed...



The arrow indicates the current selection.

The bar graph and percentage indicate the approximate level of charge in the battery.

3. Press (F1) to disable the battery saver function for continuous use.
Press (F2) to enable the battery saver function. The meter will switch itself off if no key has been pressed for five minutes.
Press (Menu) to quit the battery saver menu and retain the current setting.

Notes

1. For troubleshooting purposes, the battery volts can also be displayed in the battery saver menu. Press (F3) to display battery volts.
2. The  symbol flashes when the battery volts drops below 5.60 volts. At 5.00 volts the meter turns itself off.
3. The Battery Saver function is disabled while the meter is in Automatic Data logging mode (section 9), to stop the meter switching off while logging data. Even when the memory is full and the meter stops logging, the Battery Saver function is still disabled. This allows the data to be downloaded and the memory reset remotely.

12. Recharging the Battery

The  symbol flashes when the battery drops below 5.60 volts. The battery should be recharged at this point. If the battery is not recharged, the **WP-84** will switch itself off when the battery drops below 5.00 volts.

To recharge the battery...

1. Plug the battery charger, solar panel, or car cigarette lighter adaptor into the **Charger/RS232** socket. **DO NOT** plug into the **Sensor** socket, as this will damage the **WP-84**.
2. Charge for approximately 8 hours for full capacity. The **WP-84** has special circuitry to prevent overcharging, so the charger can be used continuously.
3. To ensure optimum battery life and capacity, the **WP-84** should only be charged once the  symbol starts to flash.

13. Clock Function

13.1 Setting the Clock

1. Select the Clock Set-up menu (Menu → F4:Setup → F2:Clock).
2. The display now shows the current date and time. The cursor starts at the day. For example...

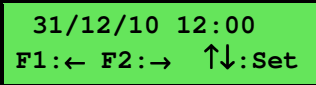

```
31/12/10 12:00
F1:← F2:→ ↑↓:Set
```

3. Press the ▲ and ▼ keys until the day is correct.
4. Press F2 to move to the month. Press the ▲ and ▼ keys until the month is correct.
5. Press F2 to move to the year. Press the ▲ and ▼ keys until the year is correct.
6. Press F2 to move to the hour. Press the ▲ and ▼ keys until the hour is correct.
7. Press F2 to move the cursor to the minutes. Press the ▲ and ▼ keys until the minutes are correct.
8. Check that the date and time are correct.

Press F2 to save the settings.

If any changes are needed, press the F1 key to move left to the desired position.

Press Menu to quit without resetting the clock.

Notes

1. The **WP-84** does not test for a valid day of the month when setting the clock (eg: attempting to enter 31/02/10 is not corrected).
2. The **WP-84** does test for leap years.

13.2 Displaying or Hiding the Clock

The date and time are normally displayed along with the Conductivity/TDS/Salinity and Temperature readings. Press F2 in normal operation to alternatively display or hide the clock.

14. Selecting k=0.1 or k=10 Sensors

The **WP-84** automatically recognises a k=1.0 sensor. The **WP-84 does not** automatically recognise k=0.1 or k=10 sensors. When a k=0.1 or k=10 sensor is used, the **WP-84** must be set to the correct k factor before use. The following procedure describes how to select a k=0.1 or k=10 sensor.

1. Switch the meter **OFF**.
2. Connect the k=0.1 or k=10 sensor.
3. Press and HOLD the **(F2)** key while switching the meter back on.
4. The k factor selection menu is now displayed (only if the k=0.1 or k=10 sensor is connected). For example...

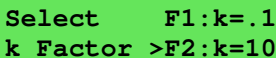

```

Select    F1:k=.1
k Factor >F2:k=10
  
```

The arrow indicates the current selection.

5. Press **(F1)** to select a k=0.1 sensor.
 Press **(F2)** to select a k=10 sensor.
 Press **(Menu)** to quit buffer selection and retain the current setting.

Notes

1. The manual k factor selection is kept in memory when the meter is switched off, even if the battery is removed.
2. The manual k factor selection is reset to k=10 during initialisation.
3. The **WP-84** will always automatically recognise a k=1.0 sensor, regardless of the manual k factor selection.
4. Calibration settings for k=0.1, k=1.0 and k=10 sensors are **NOT** stored separately. The **WP-84** requires re-calibration when a new k factor sensor is connected.
5. The message “**Connect k=10/0.1**” appears when the **WP-84** cannot detect a k=10 or k=0.1 sensor connected to the **Sensor** socket. Check that the sensor is correctly connected. If the message persists, return the k=10 or k=0.1 sensor to the factory for checking.

15. Initialising the WP-84

If the calibration settings of the **WP-84** exceed the allowable limits, the unit may need to be initialised to factory default values. This action may be required if the sensor is replaced.

To initialise the **WP-84**...

1. Switch the **WP-84** off.
2. Press and hold the  key while switching the **WP-84** back on.
3. The following messages should be displayed...

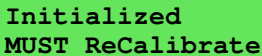

Initialized
MUST ReCalibrate

then...

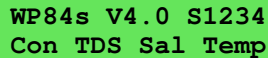

WP84s V4.0 S1234
Con TDS Sal Temp

(The “s” after **WP-84** is shown when the RS232 serial port option is fitted)

4. The meter then displays Conductivity and Temperature. Note that the decimal points have been replaced with a “*” to indicate that the unit requires re-calibration.

Note

When the **WP-84** is initialised, the manual k factor selection is re-set to k=10. See section 14 if you wish to select a k=0.1 sensor.

16. Instrument firmware version number.

If you need to email, phone or fax TPS for any further technical assistance, the version number of your **WP-84** firmware may of benefit to us. The version number is displayed by the **WP-84** at turn-on.

17. Troubleshooting

17.1 General Errors

Error Message	Possible Causes	Remedy
Factory Cal. Failed See Handbook	The EEPROM chip which contains the factory calibration information has failed.	The unit must be returned to TPS for service.
Memory Failed Calibration Lost then... Initialised MUST ReCalibrate	User calibration settings have been lost or corrupted.	Re-calibrate the instrument. A full 2-point calibration will be required for Conductivity (see section 4.1) and a 1 point calibration for temperature (see section 5.1).
Flashing  symbol.	Battery is below 5.60 volts.	Recharge the battery. Note that the unit will switch itself off when the battery falls below 5.00 volts.
Meter displays the word OFF , and switches off.	Battery is below 5.00 volts.	Recharge the battery. If this fails, check the charger. If charger OK, replace the battery.
Meter will not turn on.	<ol style="list-style-type: none"> 1. Battery is exhausted. 2. Faulty Instrument 	Recharge the battery. If this fails, check the charger. If charger OK, replace the battery. Return to factory for repair.
Battery does not charge up when charger is connected.	<ol style="list-style-type: none"> 1. Faulty battery charger or faulty battery. 2. Faulty instrument. 	<ol style="list-style-type: none"> 1. Connect the charger and switch the power on. Display the battery volts in the battery saver menu (see section 11). If the battery volts are increasing then the charger is OK. If the battery volts do not increase, then the charger is faulty. Replace the charger or the battery, as required. 2. Return to factory for repair.

17.2 Conductivity/TDS/Salinity Troubleshooting

Symptom	Possible Causes	Remedy
Unit fails to calibrate, even with new sensor.	Calibration settings outside of allowable limits due to previous failed calibration.	Initialise the unit. See section 15.
Unit attempts Span calibration instead of Zero calibration.	Sensor has Zero error.	Thoroughly rinse sensor in distilled water and allow to completely dry in air before attempting zero calibration. If instrument does not calibrate at Zero with sensor disconnected, then the instrument is faulty.
Standard calibration fails, and k factor is greater than 0.133, 1.33 or 13.3, (depending on k factor of sensor).	<ol style="list-style-type: none"> 1. Sensor is not immersed deeply enough. 2. Sensor may have a build-up of dirt or oily material on sensor wires. 3. Platinum-black coating has worn off. 4. Standard solution is inaccurate. 5. Sensor is faulty. 6. Faulty instrument. 7. k-factor incorrectly set if using k=0.1 or k=10 sensor. 	<p>Immerse sensor at least to the vent hole in the white plastic cover.</p> <p>Clean sensor, as per the instructions detailed in section 18.1.</p> <p>Sensor requires replatinisation.</p> <p>Return to the factory, or see details in section 18.2.</p> <p>Replace standard solution.</p> <p>Return sensor to factory for repair or replacement.</p> <p>Return to factory for repair.</p> <p>Set the correct k-factor, as per section 14.</p>

Continued next page...

Conductivity/TDS/Salinity Troubleshooting, continued...

Standard calibration fails, and k factor is less than 0.075, 0.75 or 7.5, (depending on k factor of sensor).	<ol style="list-style-type: none"> 1. White protective cover is not fitted or upside down. 2. Standard solution is inaccurate. 3. Sensor may have a build-up of conductive material, such as salt. 4. Sensor is faulty. 5. Faulty instrument. 6. k-factor incorrectly set if using k=0.1 or k=10 sensor. 	<p>The white protective cover MUST be fitted for correct readings. The vent hole must be towards the cable end of the sensor.</p> <p>Replace standard solution.</p> <p>Clean sensor, as per the instructions detailed in section 18.1.</p> <p>Return sensor to factory for repair or replacement.</p> <p>Return to factory for repair.</p> <p>Set the correct k-factor, as per section 14.</p>
Inaccurate readings, even when calibration is successful.	<ol style="list-style-type: none"> 1. Sensor may have a build-up of dirt or oily material on sensor wires. 2. Platinum-black coating has worn off. 	<p>Clean sensor, as per the instructions detailed in section 18.1.</p> <p>Sensor requires replatinisation.</p> <p>Return to the factory, or see details in section 18.2.</p>
Readings drift.	<ol style="list-style-type: none"> 1. Sensor may have a build-up of dirt or oily material on sensor wires. 	<p>Clean sensor, as per the instructions detailed in section 18.1.</p>
Readings are low or near zero.	<ol style="list-style-type: none"> 1. Sensor may have a build-up of dirt or oily material on sensor wires. 2. Sensor is not immersed deeply enough. 3. Sensor is faulty. 4. Faulty instrument. 5. k-factor incorrectly set if using k=0.1 or k=10 sensor. 	<p>Clean sensor, as per the instructions detailed in section 18.1.</p> <p>Immerse sensor at least to the vent hole in the white plastic cover.</p> <p>Return sensor to factory for repair or replacement.</p> <p>Return to factory for repair.</p> <p>Set the correct k-factor, as per section 14.</p>
Display flashes "ATC" and "LIMIT"	<p>The Temperature is not within the ATC limits.</p>	<p>Cool/Heat solution before taking measurements.</p>

17.3 Temperature Troubleshooting

Symptom	Possible Causes	Remedy
Displays “OVR°C” when sensor is plugged in.	<ol style="list-style-type: none">1. Faulty sensor.2. Faulty instrument.	<p>Fit new sensor.</p> <p>Return to factory for repair.</p>
Temperature inaccurate and cannot be calibrated.	<ol style="list-style-type: none">1. Faulty connector.2. Faulty sensor.3. Faulty instrument.	<p>Check the connector and replace if necessary.</p> <p>Fit new sensor.</p> <p>Return to factory for repair.</p>

18. Appendices

18.1 Care, Cleaning and Maintenance of Conductivity Sensors

18.1.1 Care of Conductivity sensors

The conductivity section of the sensor supplied with your **WP-84** consists of two platinum wires that are plated with a layer of “platinum-black”. This is quite a soft layer and is required for stable, accurate measurements. In time, the platinum-black layer may wear off in some applications, at which time the sensor will require replatinising (see section 18.2). You can help to maintain the platinum-black layer by following these simple rules:

1. **NEVER** touch or rub the sensor wires with your fingers, cloth etc.
2. Avoid using the sensor in solutions that contain a high concentration of suspended solids, such as sand or soil, which can abrade the sensor wires. Filter these types of solutions first, if possible.
3. Avoid concentrated acids. If you must measure acids, remove the sensor immediately after taking the measurement and rinse well with distilled water.

Conductivity sensors can be stored dry. Ensure that the sensor is stored in a covered container, to avoid dust and dirt build-up.

18.1.2 Cleaning of Conductivity of Sensors.

Platinised platinum Conductivity sensors can only be cleaned by rinsing in a suitable solvent. **DO NOT wipe the sensor wires**, as this will remove the platinum-black layer.

1. Rinsing in distilled water will remove most build-ups of material on the sensor wires.
2. Films of oils or fats on the sensor wires can usually be removed by rinsing the sensor in methylated spirits.
3. Stubborn contamination can be removed by soaking the sensor in a solution of 1 part Concentrated HCl and 10 parts distilled water. The sensor should not be soaked for more than approximately 5 minutes, otherwise the platinum-black layer may start to dissolve.
4. If all of these methods fail, then the last resort is to physically scrub the sensor wires, which will remove the contaminant and the layer of platinum-black. Use only a cloth or nylon scouring pad. **DO NOT USE STEEL WOOL**. The sensor will then need to be cleaned in HCl, as per step 3 and replatinised, as per section 18.2.

18.2 Replatinising Conductivity Sensors

There are several ways to replatinise Conductivity sensors.

1. The simplest way is to return the sensor to the TPS factory. We can fully clean the sensor, replatinise it and test all aspects of its performance.
2. An automatic replatiniser is available from TPS, along with replatinising solution. This will plate the sensors for the right amount of time at the correct current. Ordering details are as follows...
Automatic Conductivity Sensor Replatiniser Part No 122160
20mL Platinising Solution (suitable for approx 30 uses) Part No 122300
3. Conductivity sensors can be manually replatinised, according to the following procedure...
 - 1) Soak the sensor in a solution of 1 part Concentrated HCl and 10 parts distilled water for approximately 5 minutes.
 - 2) Rinse the sensor well in distilled water.
 - 3) Immerse the sensor in platinising solution at least to the vent hole in the white plastic cover. Platinising solution is available from TPS (part no 122300). Alternatively, platinising solution can be prepared by dissolving 1g of Hydrogen Chloroplatinate (H_2PtCl_6) in 30mL of distilled water, and including about 0.01g of Lead Acetate ($(CH_3COO)_2Pb$) and a drop or two of concentrated HCl.
 - 4) Apply a direct current of 10mA between pins 1 and 5 of the sensor plug, as per the diagram below. Reverse the polarity every 30 seconds. After approximately 8 minutes (4 minutes per sensor wire), they should have an even “soot” like appearance. Avoid excess current and this will cause incorrect platinising.
 - 5) After platinising, rinse the sensor well in distilled water.
 - 6) If you have any doubts about any of these steps, then you should consider returning the sensor to the factory. The cost of replatinising is quite low, and you will be guaranteed of the best possible result.

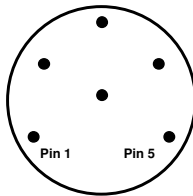

Sensor Connector

19. Warranty

TPS Pty Ltd guarantees all instruments and sensors to be free from defects in material and workmanship when subjected to normal use and service. This guarantee is expressly limited to the servicing and/or adjustment of an instrument returned to the TPS Pty Ltd Factory Service Centre, freight prepaid, within twelve (12) months from the date of delivery, and to the repairing, replacing, or adjusting of parts which upon inspection are found to be defective. Warranty period on sensors is six (6) months.

Freight costs to and from the factory are the responsibility of the purchaser. Shipping damage is not covered by this warranty.

TPS Pty Ltd accepts no liability for any incidental or consequential damages caused by or resulting from the use or misuse of this equipment either due to failure of the equipment, incorrect calibration, incorrect operation, or from interpretation of information derived from the equipment. Specifications are subject to change without notice. This warranty becomes invalid if modifications or repairs are carried out on this unit by unauthorised persons. There are no express or implied warranties which extend beyond the face hereof.

Procedure for Service

Please read service details on our '**Service**' web page first:
<http://www.tps.com.au/service.htm>

TPS Pty Ltd has a reputation for prompt and efficient service. If you feel that this equipment is in need of repair, please re-read the manual. Sometimes, instruments are received for "repair" in perfect working order. This can occur where batteries simply require replacement or re-charging, or where the sensor simply requires cleaning or replacement.

Return the instrument AND ALL SENSORS to TPS Pty Ltd freight prepaid. It is your responsibility as the sender to ensure that TPS Pty Ltd receives the unit, so consider using a trackable freight service.

Please check that the following is enclosed with your equipment:

- **A TPS 'Service / Return Goods Form' – see web link below:**
http://www.tps.com.au/Service/Service%20form_web.pdf
- **Your full name**
- **Your company name**
- **Your email address or fax number**
- **Your return street address**
- **A description of the fault. (Please be specific - "Please Repair" does not describe a fault.)**

Your equipment will be repaired and returned to you by express air freight where possible.

For instruments beyond warranty period, a repair cost will be calculated from parts and labour costs and emailed to you. If you decline to have the equipment repaired, the complete instrument will be returned to you freight paid, not serviced.

TPS Pty Ltd has only one service location, which is located at our factory in Brisbane:

Service Department

TPS Pty Ltd

4 Jamberoo Street

Springwood, QLD 4127

Australia

T: (07) 32 900 400

F: (07) 3808 4871

E: tps@tps.com.au

W: www.tps.com.au