

## **Congratulations !**

Your new **proCHEM-R** controller is the latest in simple, reliable process control instrumentation. With correct operation and maintenance, your **proCHEM-R** will give you many years of reliable service.

The **proCHEM-R** is a breeze to operate. This manual has been designed to help you get started, and also contains some handy application tips. If at any stage you require assistance, please contact either your local TPS representative or the TPS factory in Brisbane.

---

The manual is divided into the following sections:

### **1. Table of Contents**

Each major section of the handbook is clearly listed. Sub-sections have also been included to enable you to find the information you need at a glance.

### **2. Introduction**

The introduction has a diagram and explanation of the display and controls of the **proCHEM-R**. It also contains a full listing of all of the items that you should have received with the unit. Please take the time to read this section, as it explains some of items that are mentioned in subsequent sections.

### **3. Main Section**

The main section of the handbook provides complete details of the **proCHEM-R**, including operating modes, calibration, troubleshooting, specifications, and warranty terms.

### **4. Appendices**

Appendices containing background information and application notes are provided at the back of this manual.

## **proCHEM-R Process Controller**

Version : 1.0  
Date : 25-Jun-2004  
Author : MS



**TPS Pty Ltd**

ABN 30 009 773 371

4 Jamberoo Street  
Springwood, Brisbane,  
Australia, 4127

Phone : (07) 32 900 400

International : 61 7 32 900 400

Fax : (07) 3808 4871

International : 61 7 3808 4871

Email : [tps@tps.com.au](mailto:tps@tps.com.au)

Web : [www.tps.com.au](http://www.tps.com.au)

## Contents

<b>1. Introduction</b> .....	<b>4</b>
1.1 proCHEM-R Illustration .....	4
1.2 Unpacking Information .....	6
1.3 Specifications .....	7
<b>2. Operating Modes</b> .....	<b>8</b>
<b>3. Installation and Set-up</b> .....	<b>9</b>
3.1 Connection and Configuration Diagram .....	9
3.2 Mounting the Enclosure .....	10
3.3 Mounting the Sensor .....	11
3.4 Terminal Connections .....	12
3.5 Setting the Control Limit .....	15
3.6 Selecting Current or Voltage Output .....	18
3.7 Selecting Standard or Custom 4 to 20 mA Output .....	19
3.8 Calibrating the 4 to 20mA Output .....	20
3.9 CMRR (RV7) Control .....	20
3.10 Factory Configuration (J3) Jumpers .....	21
<b>4. Calibration</b> .....	<b>22</b>
4.1 Calibration Procedure .....	22
4.2 Calibration Notes .....	23
<b>5. Process Monitoring</b> .....	<b>24</b>
<b>6. Automatic Control</b> .....	<b>24</b>
<b>7. Fuse Replacement</b> .....	<b>24</b>
<b>8. Troubleshooting</b> .....	<b>26</b>
8.1 Instrument Function Troubleshooting .....	26
8.2 Redox Troubleshooting .....	27
<b>9. Warranty</b> .....	<b>28</b>
<b>10. Appendices</b> .....	<b>30</b>
10.1 Power Terminal connections when 12V DC option is fitted .....	30
10.2 Relay Output Wiring Examples for mains powered units .....	31
10.3 Relay Output Wiring Examples for 12V DC powered units .....	32

# 1. Introduction

## 1.1 proCHEM-R Illustration

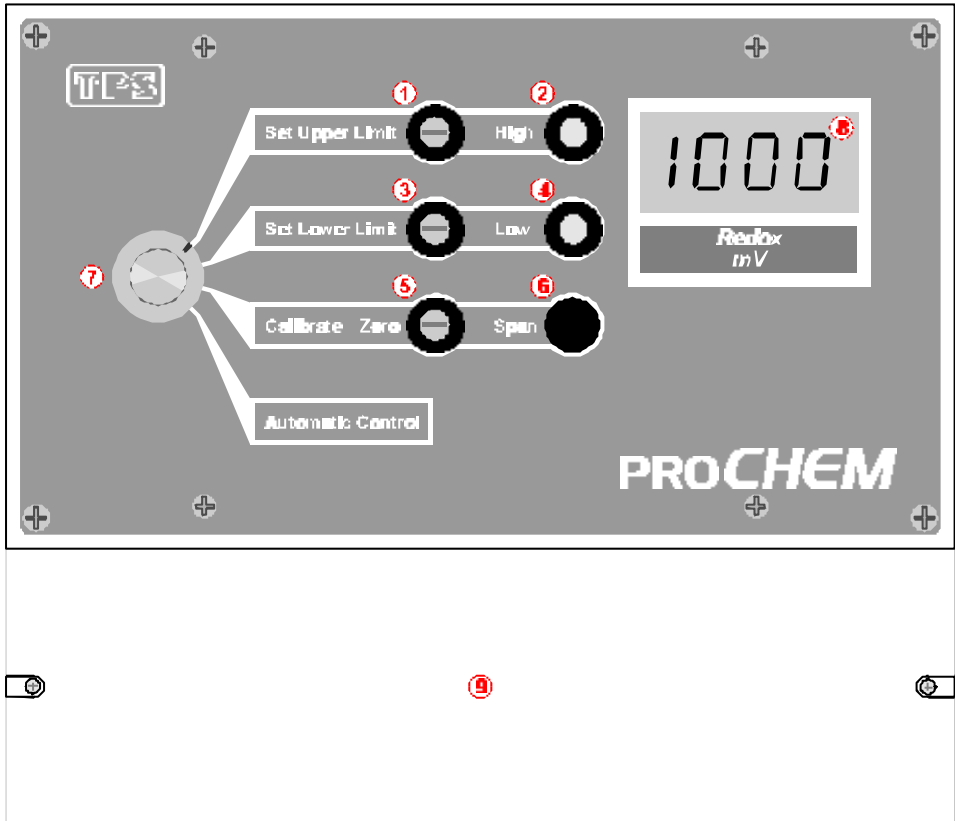

### ① **Set Upper Limit Control**

Adjust this control to the Millivolt value at which the High LED and relay output are activated. Factory-set to activate when the reading is **above** the Upper Limit. See section 3.5.

### ② **High LED**

The High LED provides visual indication of when the Upper Limit has been exceeded. Factory-set to light up when the reading is **above** the Upper Limit. See section 3.5.

### ③ **Set Lower Limit Control**

Adjust this control to the Millivolt value at which the Low LED and relay output are activated. Factory-set to activate when the reading is **below** the Lower Limit. See section 3.5.

### ④ **Low LED**

The Low LED provides visual indication of when the Lower Limit has been exceeded. Factory-set to light up when the reading is **below** the Lower Limit. See section 3.5.

### ⑤ **Zero Calibrate Control**

Adjust this control to calibrate the **proCHEM-R** in a Redox standard. See section 4.

### ⑥ **Span Calibrate Control**

This control is not required for the **proCHEM-R**.

### ⑦ **Function Switch**

The Function Switch is used to select the mode of operation. See section 2.

### ⑧ **Display Window**

The **proCHEM-R** has a large, easy to read LCD display. The units of measurement are clearly shown in the window beneath the display.

### ⑨ **Terminal Cover**

The terminal cover provides easy access to all of the connections, relay output fuses, configuration jumpers and user-adjustable trimmers. The cover is water resistant to IP65.

## 1.2 Unpacking Information

Before using your new **proCHEM-R**, please check that the following accessories have been included:

	Part No
1. <b>proCHEM-R</b> Process Controller.....	111122
2. ZoBell Redox Standard, 231mV, 200mL ea Part A & Part B.....	121309
3. <b>proCHEM-R</b> Handbook.....	130050

### ***Options that may have been ordered with your proCHEM-R:***

#### *Dip mounted Redox Sensors, and submersible assembly...*

1. Submersible, Non-flow Redox Sensor, 5m .....	111260
2. Intermediate Junction Redox Sensor, 5m .....	121267
3. Stainless Steel solution earth rod, 5m .....	121360
4. Submersible protective housing for Redox & earth rod.....	111303

#### *Screw-in Redox Sensor, and adaptor for 40mm PVC pipe...*

1. Screw-in, Non-flow Redox Sensor, 5m .....	111262
2. Stainless Steel solution earth rod, 5m (not screw-in) .....	121360
3. ¼ BSP thread adaptor for 40mm PVC pipe .....	111305

#### *Instrument options...*

1. 4-20mA loop-Rowered, remote LCD.....	130080
2. 12V DC Power Option .....	130072

### 1.3 Specifications

Range.....	0 to 1000 mV
Resolution.....	1 mV
Accuracy.....	±1 mV
Linearity.....	±1 mV
Repeatability.....	±1 mV
Ambient Drift.....	<0.02% Span per 1°C change
Long term drift.....	<0.1% per year
Input Impedance.....	>3 x 10 <sup>12</sup> Ω
Zero Range.....	±100 mV
Common Mode Rejection.....	120 dB
Enclosure.....	Polycarbonate, waterproof to IP65
Display.....	12.7 mm LCD (optional remote 4-20mA loop powered display available)
Analogue Outputs.....	4 to 20mA (500 Ohms max. loop resistance ) 0 to 1 V DC (min. load 1000 Ω) 0 to 10 V DC optional (min. load 1000 Ω)
Control Outputs.....	2 x Clean contact changeover relays, rated to 2A at 240V AC
Isolation.....	Galvanic isolation of sensor input
Power.....	240V AC, 50/60Hz (120V AC optional)
Dimensions.....	215 x 190 x 115 mm
Mass.....	Instrument only : Approx 900g Full Kit : Approx 1.5kg
Operating Environment:.....	Temperature : 0 to 45 °C Humidity : 0 to 95 % R.H.

## 2. Operating Modes

The function switch is used to select the required mode. The four operating modes available are...

1. **Set Upper Limit** : Switch to **Set Upper Limit** when setting the Millivolt value at which the High LED and relay output are activated. The relay output is not operational in this mode.  
  
Factory-set to activate when the reading is **above** the Upper Limit. Can be user set to be a activate when the reading is **below** the Upper Limit. See section 3.5.
  
2. **Set Lower Limit** : Switch to **Set Lower Limit** when setting the Millivolt value at which the Low LED and relay output are activated. The relay output is not operational in this mode.  
  
Factory-set to activate when the reading is **below** the Lower Limit. Can be user set to be a activate when the reading is **above** the Lower Limit. See section 3.5.
  
3. **Calibrate** : Switch to Calibrate mode to place the **proCHEM-R** into standby (eg. when calibrating). This mode disables the two output relays to avoid chemicals being added when placing the sensor into calibration buffers.
  
4. **Automatic Control** : Switch to **Automatic Control** to enable the Alarm LED's and relay outputs. These will be activated when the Millivolt reading is outside the Upper and Lower limit values. See section 3.5.

### 3. Installation and Set-up

#### 3.1 Connection and Configuration Diagram

The diagram below is provided as a reference for the terminal connections, configuration jumpers and user-adjustable trimmers that are discussed throughout this section.

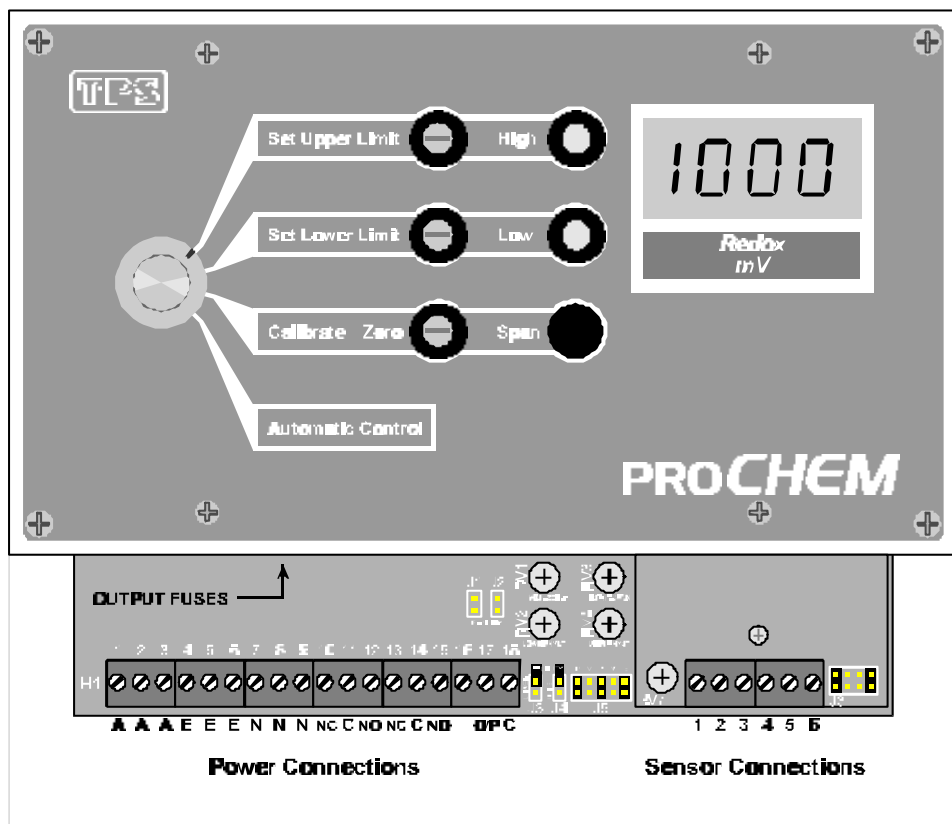

### 3.2 Mounting the Enclosure

The **proCHEM-R** can be wall-mounted with 3 screws. Two mounting points are located underneath the terminal cover, and are positioned so that they do not affect the waterproofing of the enclosure. The third mounting point is centrally located near the top of the rear of the enclosure, and has been designed to hook over a screw-head. The dimensions for the mounting screw centres are provided on the rear of the enclosure, and are also illustrated below...

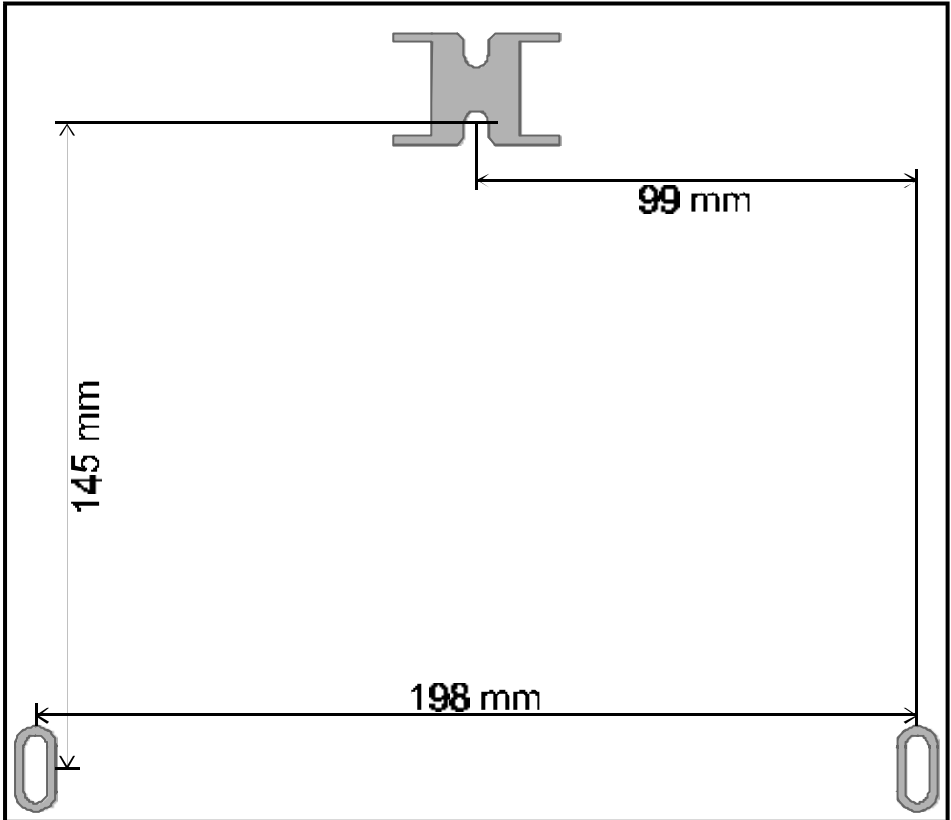

### 3.3 Mounting the Sensor

Mounting the sensors is a very important aspect of the installation, and is often done incorrectly. In automatic control situations, the sensor should always be mounted as close as possible to the injection point. This will cause the sensor to detect the added chemicals immediately, and shut the addition off until mixing has taken place. For in-line mounting, it is important that chemicals are injected upstream. Additionally, the line must be run through a mixing chamber, such as a large drum, to ensure that the injected chemical has mixed in properly by the time the solution flows past the sensor. There must always be adequate flow of fresh sample past the sensor, for accurate monitoring. The diagrams below show typical mounting arrangements for “dip” mounting and in-line mounting.

#### *Dip Mounting*

1. Injection point close to sensor.
2. Submersible housing to protect sensors and waterproof rear of cable (part no 111303).
3. Continuous stirring.

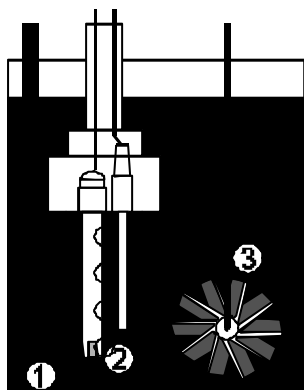

#### *In-line Mounting*

1. Injection point upstream from and close to sensor.
2. Mixing container after injection and before sensor.
3. Redox sensor mounted as close to vertical as practical.

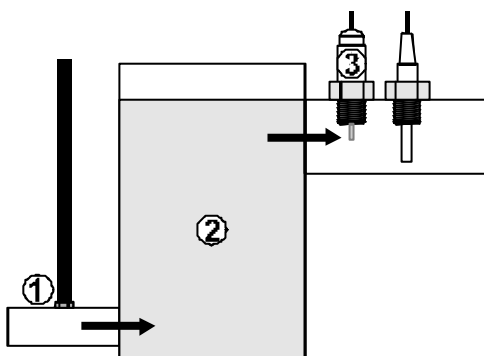

### 3.4 Terminal Connections

#### 3.4.1 Power Connections

All power connections are on the main terminal block (H1), which has 18 terminals.

**Note: The power connections detailed below are for normal mains power. Refer to section 10.1 for power wiring details when the 12V DC power option is fitted.**

Terminal No.	Connection	Colour
1	220 / 240V AC Active input	Brown (standard colour)
2	Duplicate 240V AC Active contact.	Brown (standard colour)
3	Duplicate 240V AC Active contact.	Brown (standard colour)
4	220 / 240V AC Earth input	Green (standard colour)
5	Duplicate 240V AC Earth contact.	Green (standard colour)
6	Duplicate 240V AC Earth contact.	Green (standard colour)
7	220 / 240V AC Neutral input	Blue (standard colour)
8	Duplicate 240V AC Neutral contact.	Blue (standard colour)
9	Duplicate 240V AC Neutral contact.	Blue (standard colour)
10	Normally Closed contact of Lower relay output	Customer Defined
11	Common contact of Lower relay output	Customer Defined
12	Normally Open contact of Lower relay output	Customer Defined
13	Normally Closed contact of Upper relay output	Customer Defined
14	Common contact of Upper relay output	Customer Defined
15	Normally Open contact of Upper relay output	Customer Defined
16	No Connection	
17	+ve of current or voltage output	Customer Defined

18	-ve of current or voltage output	Customer Defined
----	----------------------------------	------------------

### 3.4.2 Sensor Connections

All sensor connections are on the 6-way terminal block which is on the right hand side of the enclosure.

<b>Terminal No.</b>	<b>Connection</b>	<b>Colour</b>
1	No Connection	
2	No Connection	
3	Solution Guard	Customer-defined. Green is recommended.
4	Redox Shield (if fitted)	Green
5	Redox Reference	Black
6	Rdox Signal	Clear or White

### 3.5 Setting the Control Limit

The Upper and Lower control limits can both be set over the full scale of the **proCHEM-R**. The unit is set up in the factory for the Upper Limit LED and relay to be activated when the reading rises **above** the Upper Limit. Similarly, the Lower Limit LED and relay are factory set to be activated when the reading drops **below** the Lower Limit.

See section 3.5.3 for details on how to re-set the Upper or Lower limits for the reverse of the default direction.

The hysteresis around the set point can be also be adjusted if necessary. See section 3.5.4 for an explanation of hysteresis.

#### 3.5.1 *Setting the Upper Limit value*

1. Switch the **proCHEM-R** to **Set Upper Limit**.

The Upper Limit value is now displayed. Note that the Alarm LED and output relays are now disabled. The 4-20mA or 0-1V outputs are still active, and proportional to displayed value.

2. Adjust the **Set Upper Limit** control until the display reads the desired set point value.

#### 3.5.2 *Setting the Lower Limit value*

1. Switch the **proCHEM-R** to **Set Lower Limit**.

The Lower Limit value is now displayed. Note that the Alarm LED and output relays are now disabled. The 4-20mA or 0-1V outputs are still active, and proportional to displayed value.

2. Adjust the **Set Lower Limit** control until the display reads the desired set point value.

### 3.5.3 Reversing the default control direction

The Upper Limit control action can be reversed to activate the Upper Limit LED and relay when the reading drops **below** the Upper Limit.

Similarly, the Lower Limit control action can be reversed to activate the Lower Limit LED and relay when the reading rises **above** the Lower Limit.

Having two Limits acting in the same direction can be very useful for processes where the readings always drift in one direction. It allows the operator to set the first Limit as a control point (eg to start a dosing pump), and the second limit beyond that as an alarm point, in case the control action was not effective.

The **proCHEM-R** must be switched OFF before changing jumper settings.

To reverse the action of the Lower Limit, and have two Limits that activate the High and Low LED's and relays when the reading rises **above** the Limits, set the J3 and J4 jumpers as shown.

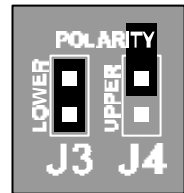

To reverse the action of the Upper Limit, and have two Limits that activate the High and Low LED's and relays when the reading drops **below** the Limits, set the J3 and J4 jumpers as shown.

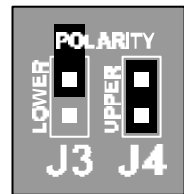

To re-set the action of the Upper and Lower limits to factory defaults, set the J3 and J4 jumpers as shown

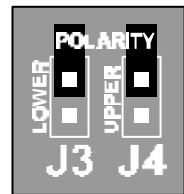

### **3.5.4 Adjusting the Hysteresis**

The hysteresis is the Redox range over which the alarm/control output remains switched on, once the trip point has been exceeded.

For example, if the Lower Limit is set to 700mV, with a hysteresis of 10mV, the alarm/control output is switched ON when the reading goes to 690mV (i.e. 700 - 10). The output is not switched OFF until the reading goes back up to 710mV (i.e. 700 + 10).

The hysteresis stops the relay “chattering” around the set point, by providing a buffer between the points at which the output is switched ON and OFF. This feature can significantly increase the life of pumps and solenoid valves.

The factory-set hysteresis is approximately  $\pm 10\text{mV}$ , as in the example above. The hysteresis can be increased to as high as  $\pm 40\text{mV}$  with the relevant **LOWER HYST** (RV2) or **UPPER HYST** (RV4) trimmers in the terminal area. Turning the trimmer clockwise increases the hysteresis and turning it anti-clockwise decreases the hysteresis.

***TPS DOES NOT recommend that this setting be altered, unless it is absolutely necessary.***

The hysteresis trimmer should only be adjusted a little at a time. The process being controlled should then be closely monitored over a time to ensure that the desired control is being achieved.

### 3.6 Selecting Current or Voltage Output

The **Current/Voltage Output** jumpers in terminal section can be user-set for either 4 to 20mA or 0 to 1V DC output. The **proCHEM-R** must be switched OFF before changing jumper settings.

The jumper settings for 4 to 20 mA output are:

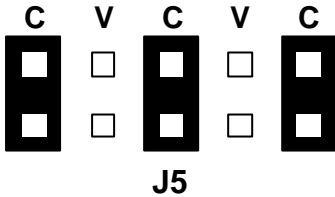

The jumper settings for 0 to 1V DC output are:

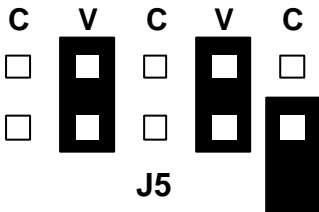

Note that the spare jumper has been fitted to a spare **Current/Voltage Output** jumper pin. This is a safe place to keep it, in case the **proCHEM-R** needs to be reset to current output in the future.

### 3.7 Selecting Standard or Custom 4 to 20 mA Output

The **proCHEM-R** is normally supplied to provide 4 to 20 mA for the full scale of the readout. If a custom 4 to 20 mA output (eg. 4 to 20 mA output for 600mV to 800mV) is supplied, the user can still change between this custom output and the normal 4 to 20 mA output for full scale.

The jumper settings for the standard 4 to 20 mA output are...

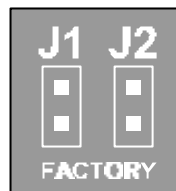

The jumper settings for the custom 4 to 20 mA output are...

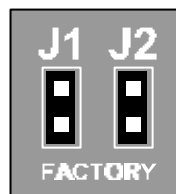

### 3.8 Calibrating the 4 to 20mA Output

The 4 to 20mA output of the **proCHEM-R** is factory calibrated. However, TPS has provided calibration controls for the 4mA and 20mA points in case this requires adjustment in the field.

#### ***Calibrating the 4 to 20mA output...***

1. Connect a Digital Milliamp Meter between terminals 17 and 18.
2. Switch the **proCHEM-R** to **Set Upper Limit**.
3. Adjust the **Set Upper Limit** control until the display reads 0 (for the standard 4 to 20mA output) or the Millivolts that corresponds to 4 mA (for a custom 4 to 20 mA output).
4. Adjust the **4-20mA ZERO** (RV1) trimmer in the terminal area until the Digital Milliamp Meter reads 4 mA.
5. Adjust the **Set Upper Limit** control until the display reads 1000 (for the standard 4 to 20mA output) or the Millivolts that corresponds to 20 mA (for a custom 4 to 20 mA output).
6. Adjust the **4-20mA SPAN** (RV3) trimmer in the terminal area until the Digital Milliamp Meter reads 20 mA.

*In the event that the **LIMIT** control does not have sufficient adjustment to reach 0 or 1000, calculate the expected output level and use this for calibration. Remember that the difference between 0 and 1000mV is to be made 16mA.*

### 3.9 CMRR (RV7) Control

The Common Mode Rejection Ratio (CMRR) is factory-set with the CMRR trimmer (RV7).

**DO NOT ATTEMPT TO ADJUST THE CMRR (RV7) TRIMMER.**

If this trimmer is accidentally re-set, the unit would best be returned to the factory for re-calibration.

### 3.10 Factory Configuration (J3) Jumpers

The Factory Configuration (J3) jumpers are factory set, and must not be altered. In case any of these jumpers are changed or removed, re-fit them as shown below. The **proCHEM-R** must be switched OFF before changing jumper settings.

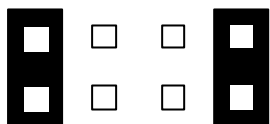

**J3**

## 4. Calibration

### 4.1 Calibration Procedure

1. Switch the **proCHEM-R** on.
2. Connect the Redox sensor and ensure that a solution guard rod is fitted. (see section 3.4.2). Remove the wetting cap from the Redox sensor.
3. Set the function switch to **Calibrate**, to ensure that the relay output is not activated during calibration.
4. Rinse the Redox sensor and Guard Rod in distilled water and blot them dry.
5. Make up a 1:1 solution of ZoBell Part A and ZoBell Part B. If a small vessel is used for calibration, around 10mL of each should suffice.
6. Place the sensor and guard rod into a small sample of ZoBell standard, so that the Platinum wire and reference junction are both covered (see diagram below).

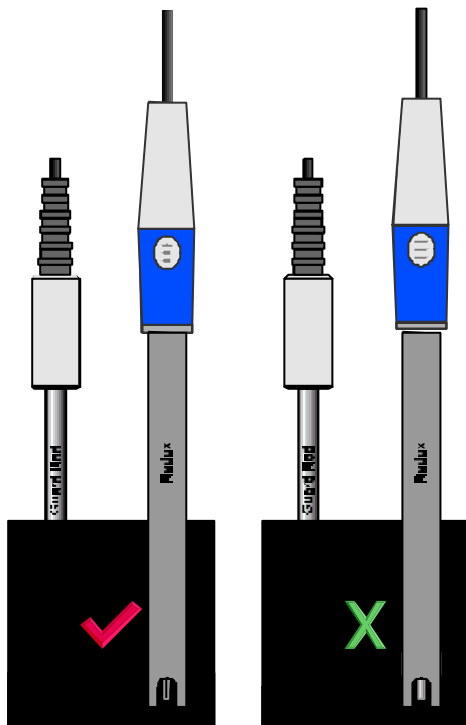

7. When the reading has stabilised, adjust the **ZERO** control until the display shows the value of the ZoBell standard. This will be one of the following...
  - a) 231 mV for Ag/AgCl reference systems filled with saturated KCl.  
(All of the Redox sensors listed in section 1.2 are this type.)
  - b) 186 mV for Ag/AgCl reference systems filled with 1 Molar KCl.
  - c) 186 mV for Calomel reference systems.
7. Rinse the Redox sensor and guard rod in distilled water and blot them dry.
8. Discard the used made-up ZoBell standard.
9. The **proCHEM-R** is now calibrated and ready for Redox measurements.

#### 4.2 Calibration Notes

1. Calibration should be performed at least weekly. In applications where the electrode junction can become blocked, such as dairy products, mining slurries etc, an asymmetry calibration may have to be done daily.

## 5. Process Monitoring

Once the **proCHEM-R** has been installed, connected and calibrated, it can be used for continuous monitoring. To monitor the process, **WITHOUT** any control or alarm functions switch the function switch to **Calibrate**.

## 6. Automatic Control

For Automatic Alarming or Control, switch the function switch to **Automatic Control** to enable the Alarm LED's and the relay outputs. These will be switched ON while the Millivolt reading exceeds the limit value, and will switch OFF once the Millivolt reading is back within the limit.

## 7. Fuse Replacement

If the current drain from any device connected to the output relay exceeds 1 Amp, the output protection fuse will blow.

To replace the fuse...

1. SWITCH THE **proCHEM-R** OFF.
2. Remove the main front panel by unscrewing the 4 screws at each corner and pulling out. Caution : The front circuit board is connected to the rear circuit board with a ribbon cable, so care must be taken.

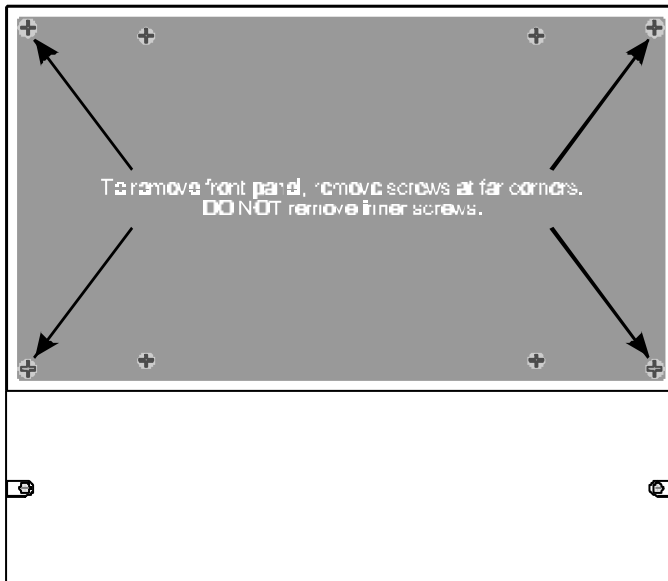

3. Locate the fuse holders, and pull out the black fuse carrier of the blown fuse.

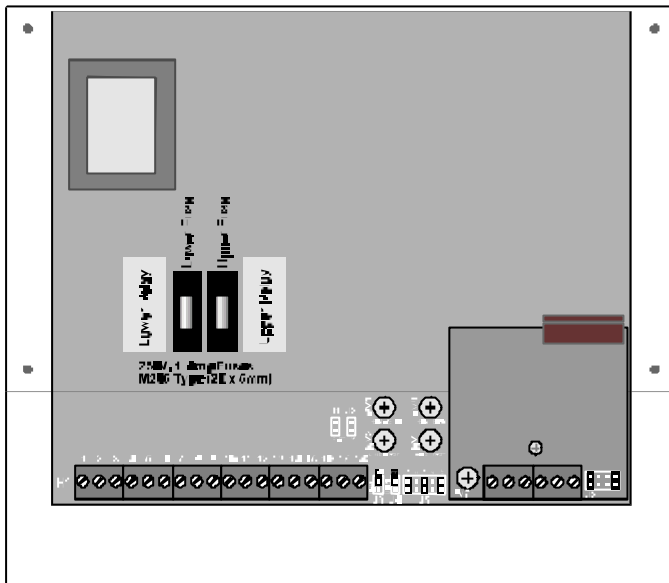

4. Replace the blown fuse with a 250V 1 Amp, M205 type. M205 fuses are 20 x 5 mm.
5. Push the fuse carrier with the new fuse back into place.

**ALWAYS REPLACE THE FUSE WITH A 1 AMP, 240V FUSE. USING A FUSE WITH HIGHER CURRENT RATING MAY DAMAGE YOUR CONTROLLER, VOIDING THE WARRANTY.**

Before switching the **proCHEM-R** back to **Automatic Control** mode, ensure that the cause of the blown fuse has been eliminated.

If the current drain of the device connected to the relay output is greater than 1 Amp, an external contactor should be used. Please consult an electrical contractor or TPS for details.

## 8. Troubleshooting

### 8.1 Instrument Function Troubleshooting

Symptom	Possible Causes	Remedy
No display	<ol style="list-style-type: none"> <li>1. Mains power input not switched on.</li> <li>2. Mains power input incorrectly connected.</li> <li>3. Instrument is faulty.</li> </ol>	<p>Switch power ON.</p> <p>Check connections (see section 3.4.1).</p> <p>Return to TPS for repair.</p>
Alarm LED or relay output do not operate when limit is exceeded.	<ol style="list-style-type: none"> <li>1. Limit not set correctly for "too high" or "too low" alarm/control.</li> <li>2. Hysteresis too large.</li> <li>3. Fuse has blown.</li> <li>4. Instrument is faulty.</li> </ol>	<p>Set the <b>J3</b> or <b>J4 Polarity</b> jumpers correctly (see section 3.5.3 ).</p> <p>Check and adjust the Hysteresis trimmer (see section 3.5.4). If in doubt, set this to minimum level.</p> <p>Check and replace fuse if necessary (see section 7).</p> <p>Return to TPS for repair.</p>
Incorrect analogue output signal.	<ol style="list-style-type: none"> <li>1. <b>Current/Voltage Output</b> jumpers incorrectly set for required output.</li> <li>2. 4-20mA loop resistance too high.</li> <li>3. Load on 0-1V DC output is too low.</li> <li>4. 4-20mA output is not calibrated.</li> <li>5. Instrument is faulty.</li> </ol>	<p>Check that the Current/Voltage Output jumpers are correctly set for 4-20mA or 0-1V, as per requirements. Adjust if necessary (see section 3.6).</p> <p>Ensure loop resistance does not exceed 500 Ohms.</p> <p>Ensure load is 1000 Ohms minimum.</p> <p>Calibrate 4-20mA output (see section 3.7).</p> <p>Return to TPS for repair.</p>

## 8.2 Redox Troubleshooting

Symptom	Possible Causes	Remedy
Calibration fails (insufficient range with <b>ZERO</b> control).	<ol style="list-style-type: none"> <li>Reference junction blocked.</li> <li>Reference electrolyte contaminated.</li> </ol>	<p>Clean reference junction, as per instructions supplied with the electrode.</p> <p>Flush with distilled water and replace electrolyte.</p>
Unstable readings.	<ol style="list-style-type: none"> <li>Solution guard not fitted.</li> <li>Reference junction blocked.</li> <li>Platinum tip not clean.</li> <li>Reference junction not immersed.</li> </ol>	<p>Connect a solution guard rod to terminal 3 (see section 3.4.2).</p> <p>Clean reference junction, as per instructions supplied with the electrode.</p> <p>Clean Platinum tip as per instructions supplied with the electrode.</p> <p>Ensure that the Platinum tip AND the reference junction are fully immersed.</p>
Inaccurate readings, even when calibration is successful.	Reference junction blocked.	Clean reference junction, as per instructions supplied with the electrode.
Displays around Zero mV in all solutions	Electrical short inside electrode or in cable.	Test system with a new electrode and replace if necessary.

## **9. Warranty**

TPS Pty. Ltd. guarantees all instruments and electrodes to be free from defects in material and workmanship when subjected to normal use and service. This guarantee is expressly limited to the servicing and/or adjustment of an instrument returned to the Factory, or Authorised Service Agent, freight prepaid, within twelve (12) months from the date of delivery, and to the repairing, replacing, or adjusting of parts which upon inspection are found to be defective. Warranty period on electrodes is three (3) months.

There are no express or implied warranties which extend beyond the face hereof, and TPS Pty. Ltd. is not liable for any incidental or consequential damages arising from the use or misuse of this equipment, or from interpretation of information derived from the equipment.

Shipping damage is not covered by this warranty.

### **PLEASE NOTE:**

A guarantee card is packed with the instrument or electrode. This card must be completed at the time of purchase and the registration section returned to TPS Pty. Ltd. within 7 days. No claims will be recognised without the original guarantee card or other proof of purchase. This warranty becomes invalid if modifications or repairs are attempted by unauthorised persons, or the serial number is missing.

### **PROCEDURE FOR SERVICE**

If you feel that this equipment is in need of repair, please re-read the manual. Sometimes, instruments are received for "repair" in perfect working order. This can occur where batteries simply require replacement or re-charging, or where the electrode simply requires cleaning or replacement.

TPS Pty. Ltd. has a fine reputation for prompt and efficient service. In just a few days, our factory service engineers and technicians will examine and repair your equipment to your full satisfaction.

**TO OBTAIN THIS SERVICE, PLEASE FOLLOW THIS PROCEDURE:**

Return the instrument AND ALL SENSORS to TPS freight pre-Raid and insured in its original packing or suitable equivalent. INSIST on a proof of delivery receipt from the carrier for your protection in the case of shipping claims for transit loss or damage. It is your responsibility as the sender to ensure that TPS receives the unit.

Please check that the following is enclosed with your equipment:

- **Your Name and daytime phone number.**
- **Your company name, ORDER number, and return street address.**
- **A description of the fault. (Please be SPECIFIC.)**  
**(Note: "Please Repair" does NOT describe a fault.)**

Your equipment will be repaired and returned to you by air express where possible.

For out-of-warranty units, a repair cost will be calculated from parts and labour costs. If payment is not received for the additional charges within 30 days, or if you decline to have the equipment repaired, the complete unit will be returned to you freight paid, not repaired. For full-account customers, the repair charges will be debited to your account.

- **Always describe the fault in writing.**
- **Always return the sensors with the meter.**

**10. Appendices****10.1 Power Terminal connections when 12V DC option is fitted**

<b>Terminal No.</b>	<b>Connection</b>
1	Negative of 12V DC Input
2	No connection for 12V DC version.
3	No connection for 12V DC version.
4	No connection for 12V DC version.
5	No connection for 12V DC version.
6	No connection for 12V DC version.
7	Positive of 12V DC Input
8	No connection for 12V DC version.
9	No connection for 12V DC version.
10	Normally Closed contact of Lower relay output
11	Common contact of Lower relay output
12	Normally Open contact of Lower relay output
13	Normally Closed contact of Upper relay output
14	Common contact of Upper relay output
15	Normally Open contact of Upper relay output
16	No Connection
17	+ve of current or voltage output
18	-ve of current or voltage output

## 10.2 Relay Output Wiring Examples for mains powered units

The diagrams below provide some examples of wiring the relay outputs for standard mains powered **proCHEM-R** units.

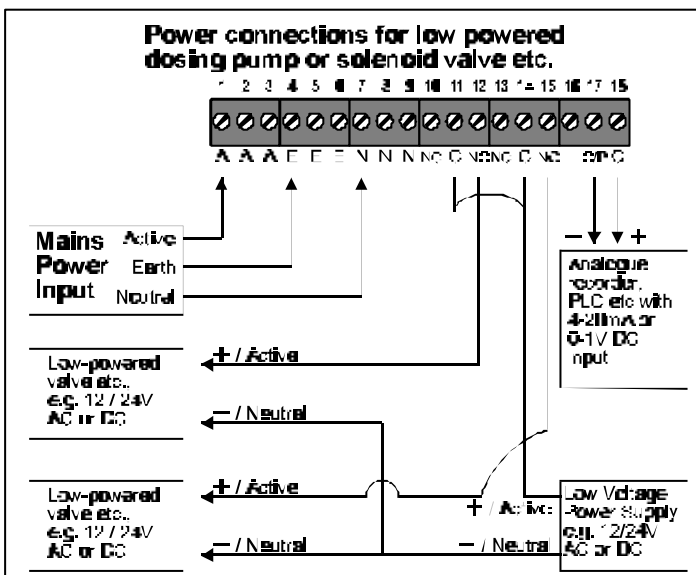
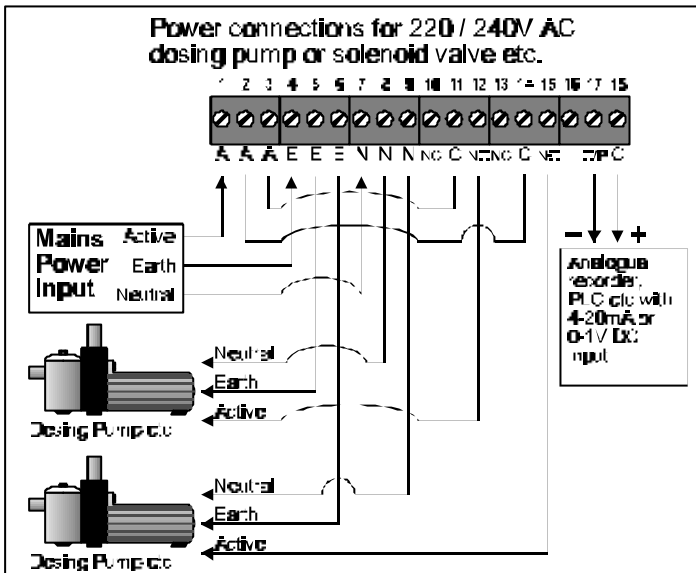

### 10.3 Relay Output Wiring Examples for 12V DC powered units

The diagrams below provide some examples of wiring the relay output for **proCHEM-R** units with the 12V DC power option.

